

TYPICAL A UNIT

APPROX. SQ. FT.	
LIVING AREA	1650
NON-LIVING AREA	+250
TOTAL	1900

0' 3' 6' 12'
 Approximate Scale: 1" = 12'

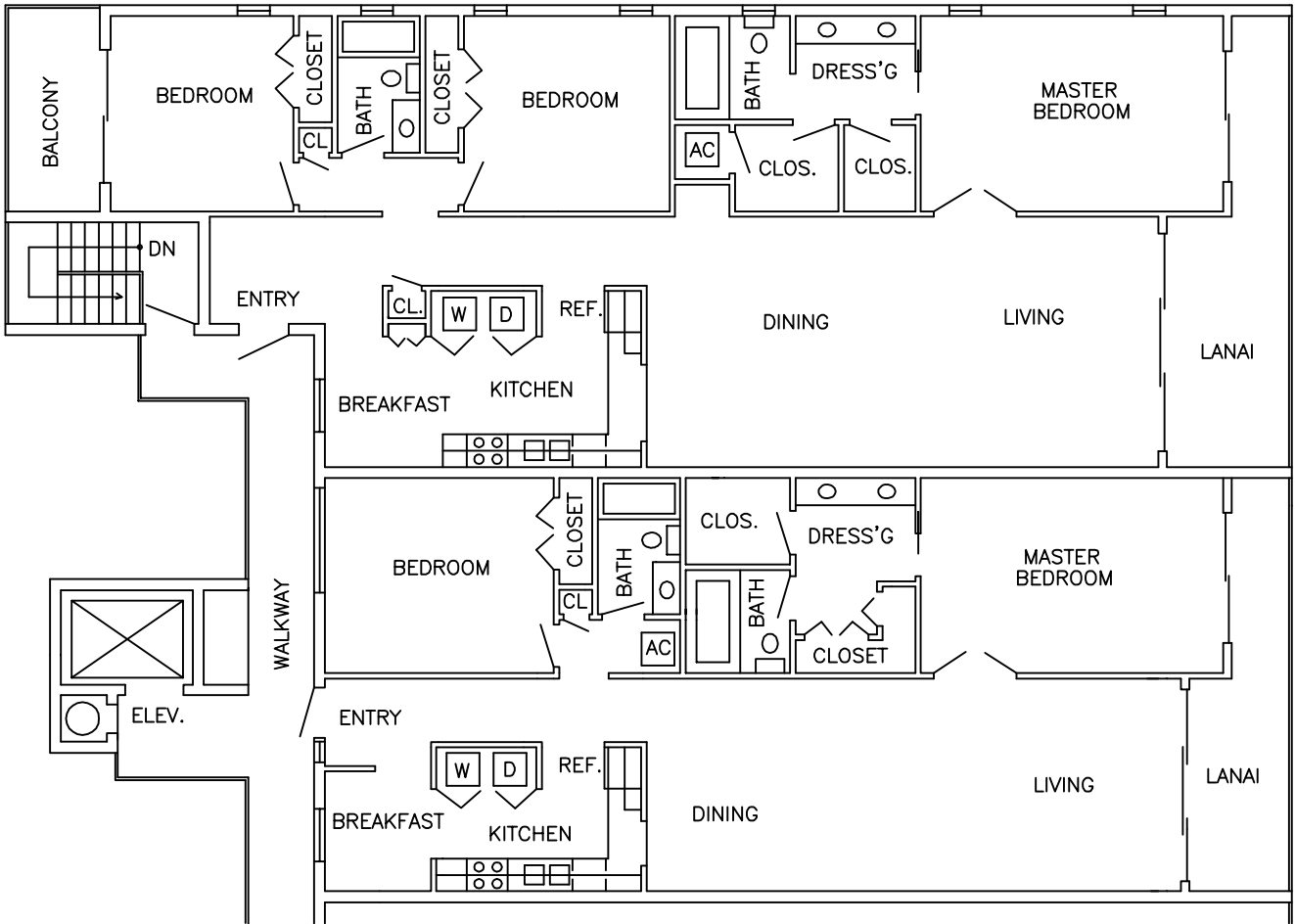

TYPICAL B UNIT

APPROX. SQ. FT.	
LIVING AREA	1200
NON-LIVING AREA	+250
TOTAL	1450

0' 3' 6' 12'
 Approximate Scale: 1" = 12'

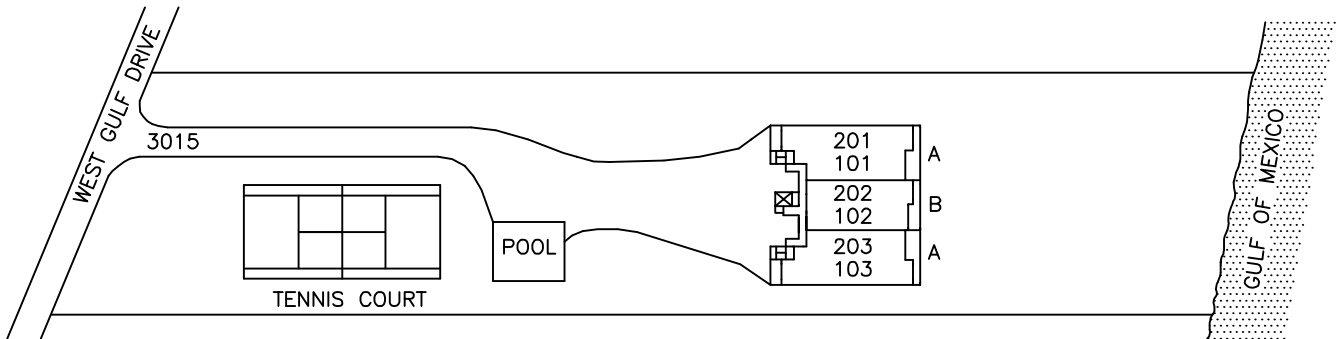

SITE PLAN
 NO SCALE

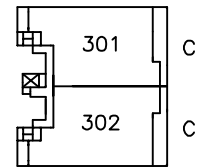

3rd FLOOR

PART PLAN

(8 Units)
 SUNWARD OF SANIBEL-142